

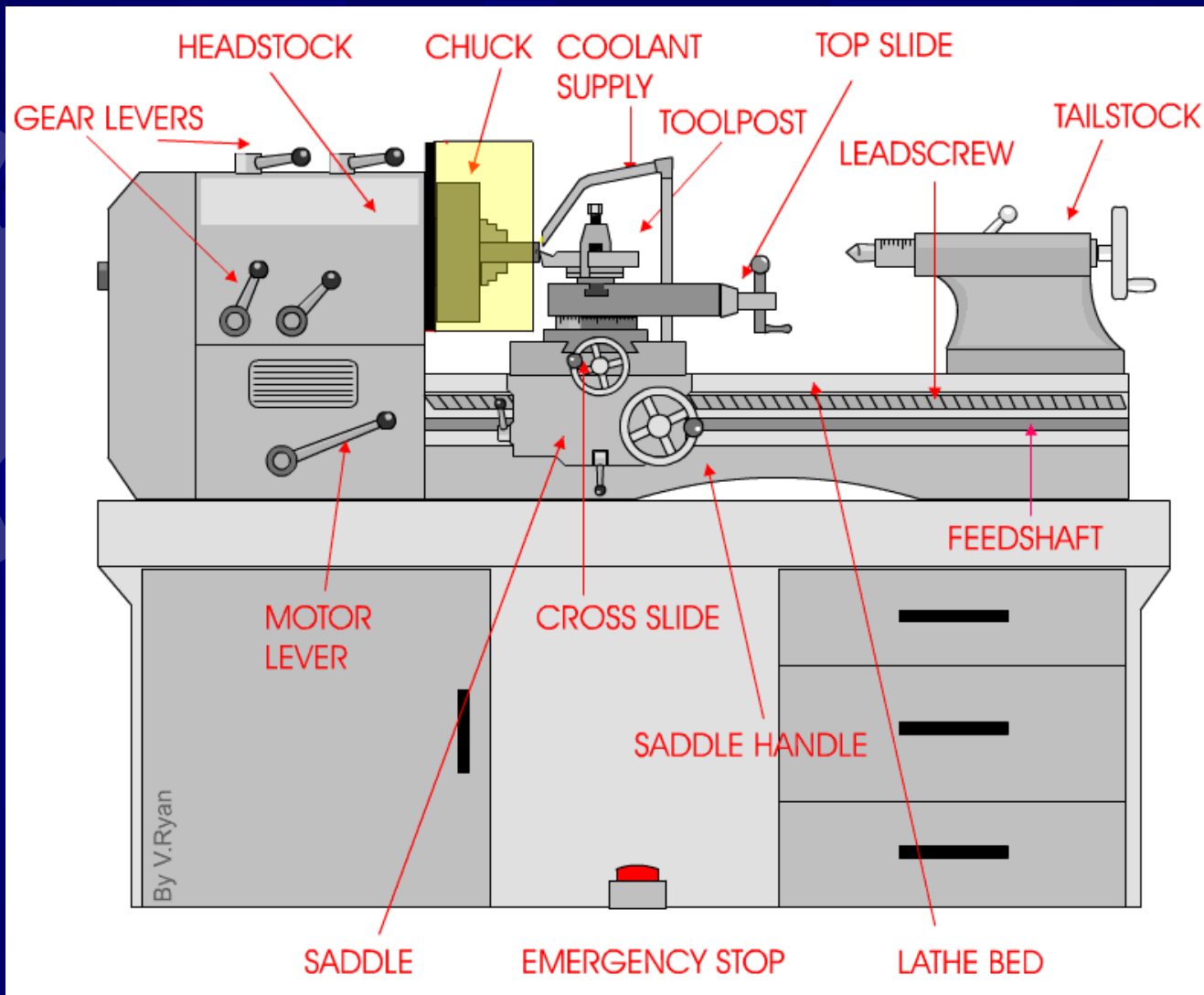

Beginning Machining

- Metal Lathes

Machine Layout



Machine Speeds

- Belt Drive vs Gear Drive

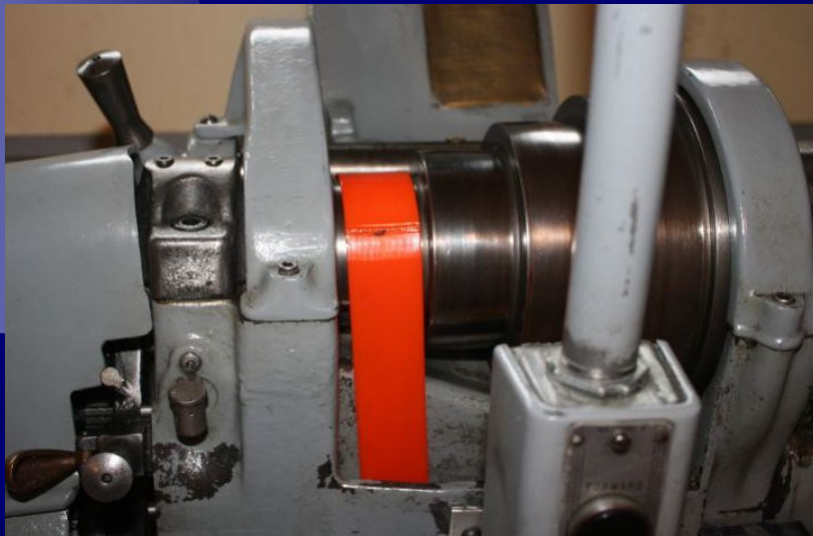

Spindle Reversing



Major Adjustments

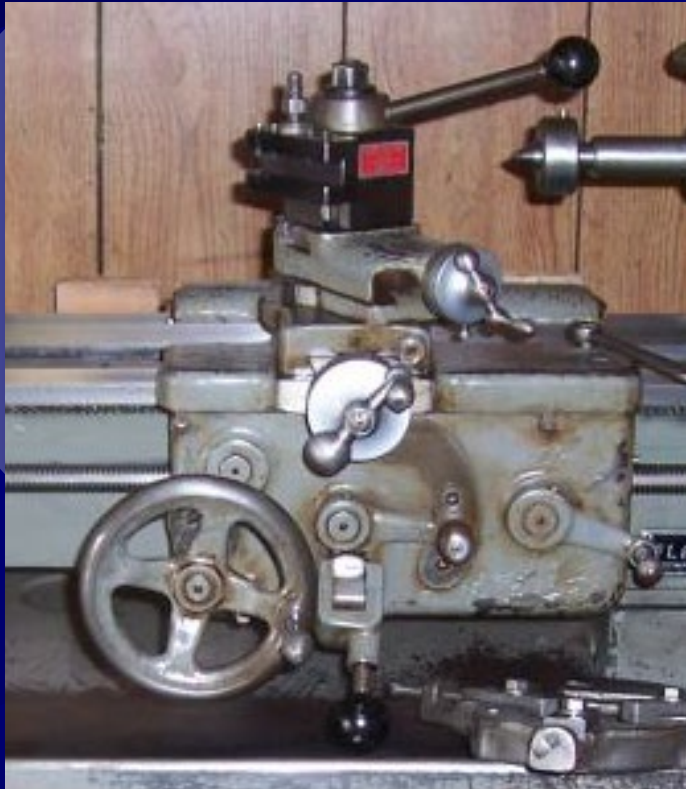

Tool Holding

- Tool Posts
 - Rocker
 - 4 Way
 - Quick Change



Work Holding

- Collet Closer
- Chucks
- Faceplate



I am my own best friend...

A metal lathe is the only tool in the shop that can reproduce itself...

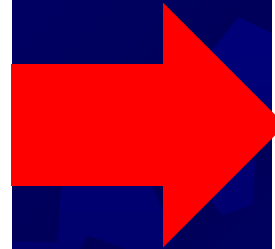

Additional Common Accessories

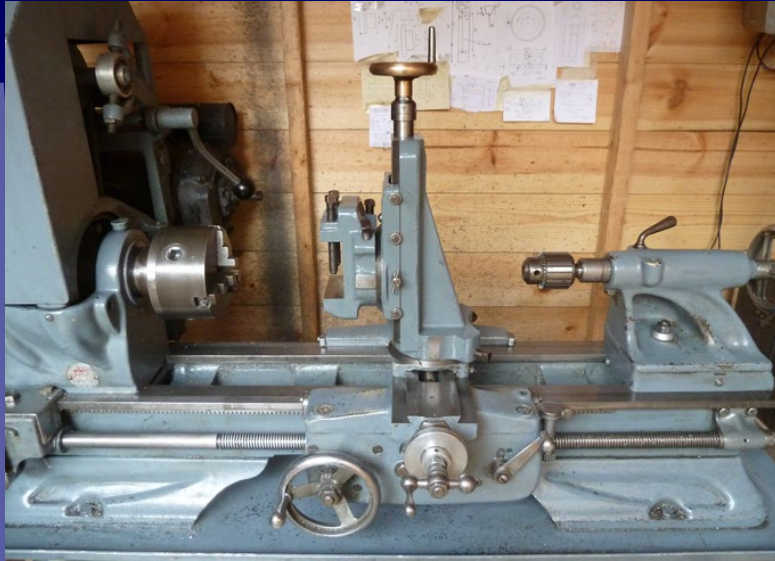

Milling Attachment

Taper Attachment



Facing

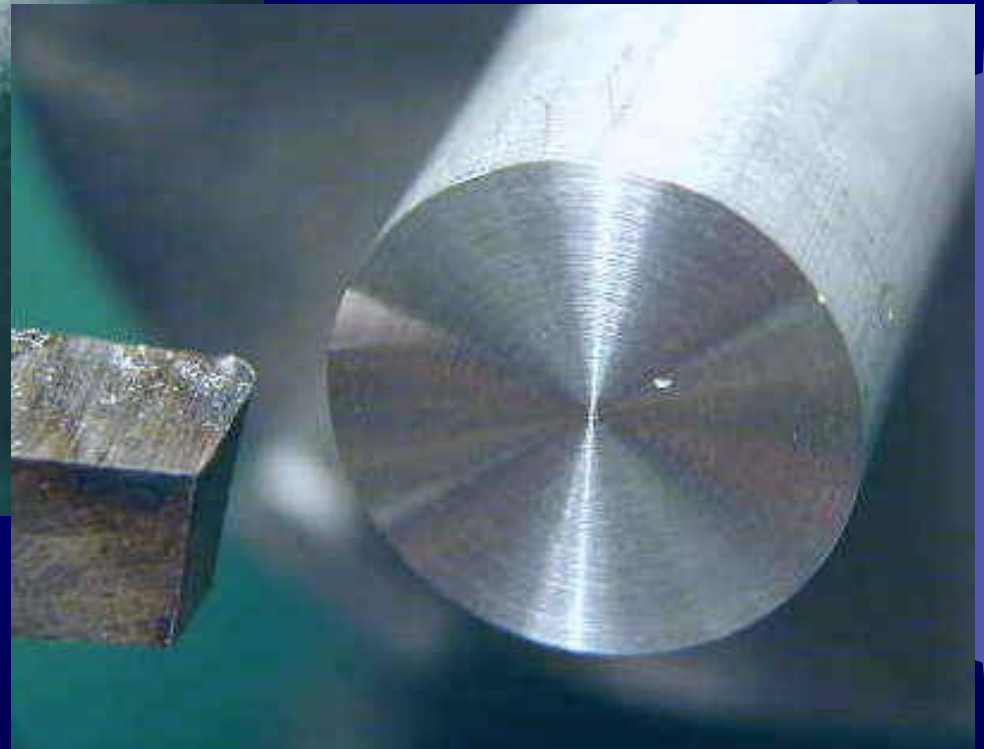
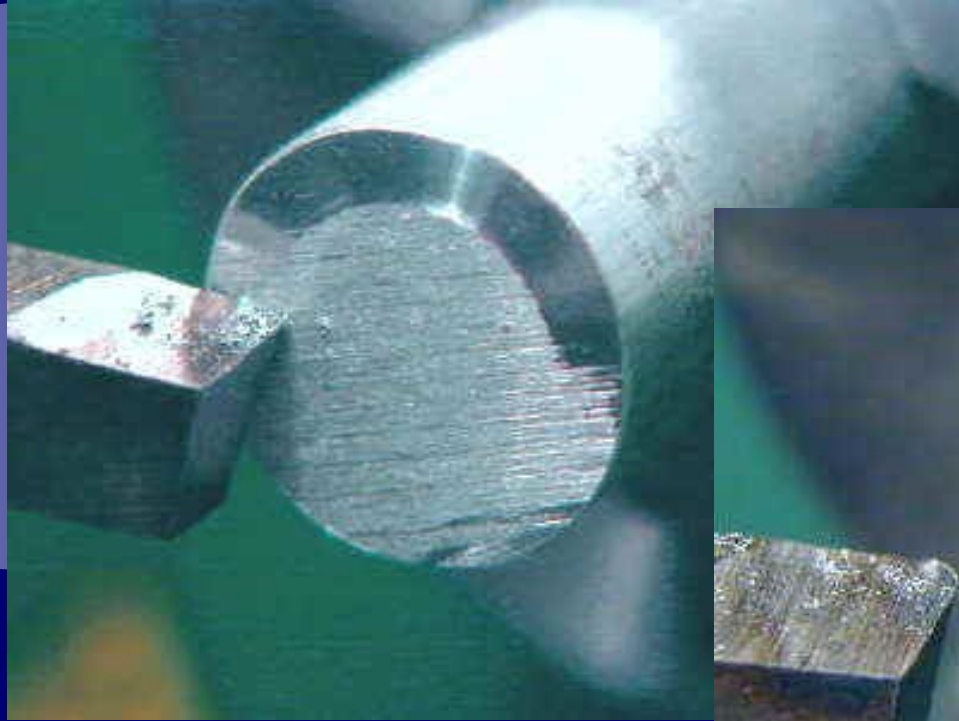

Turning

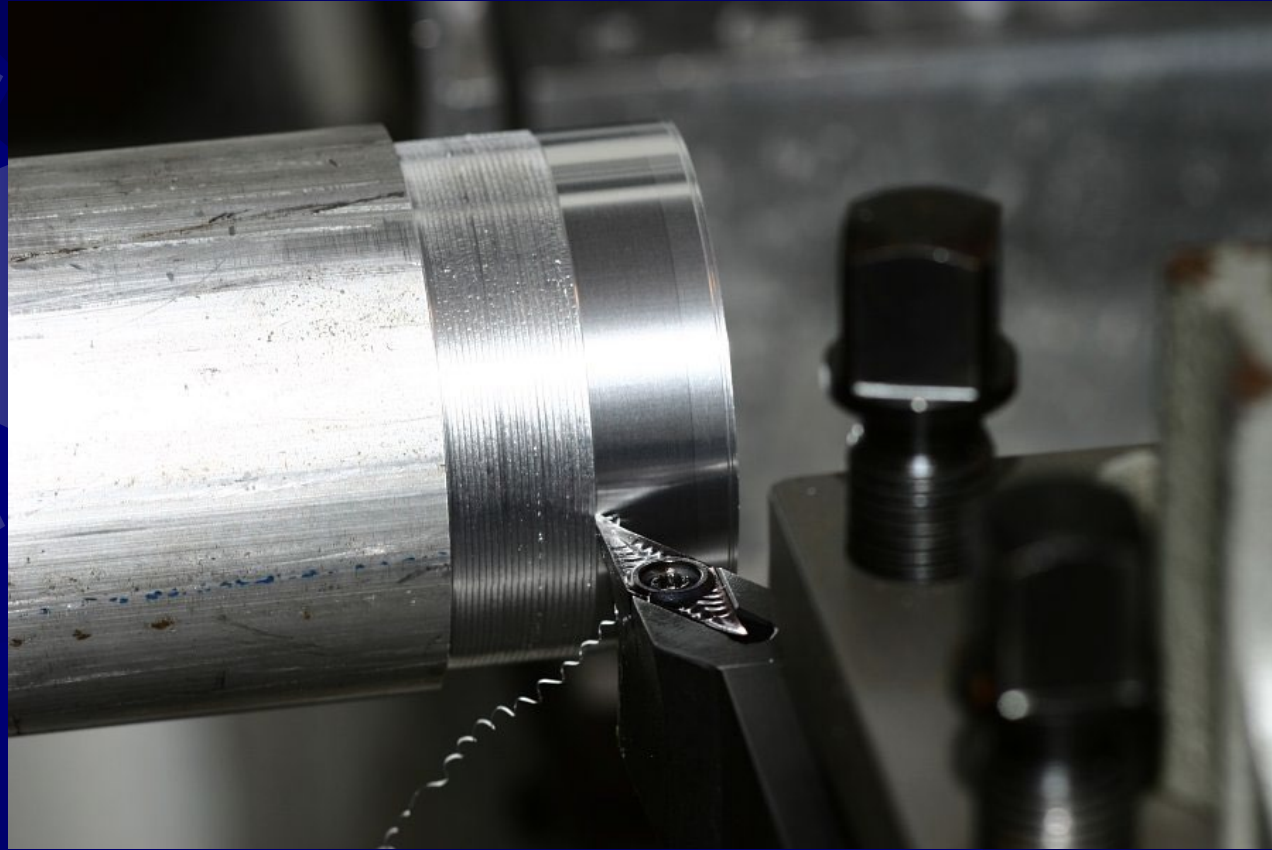

Threading

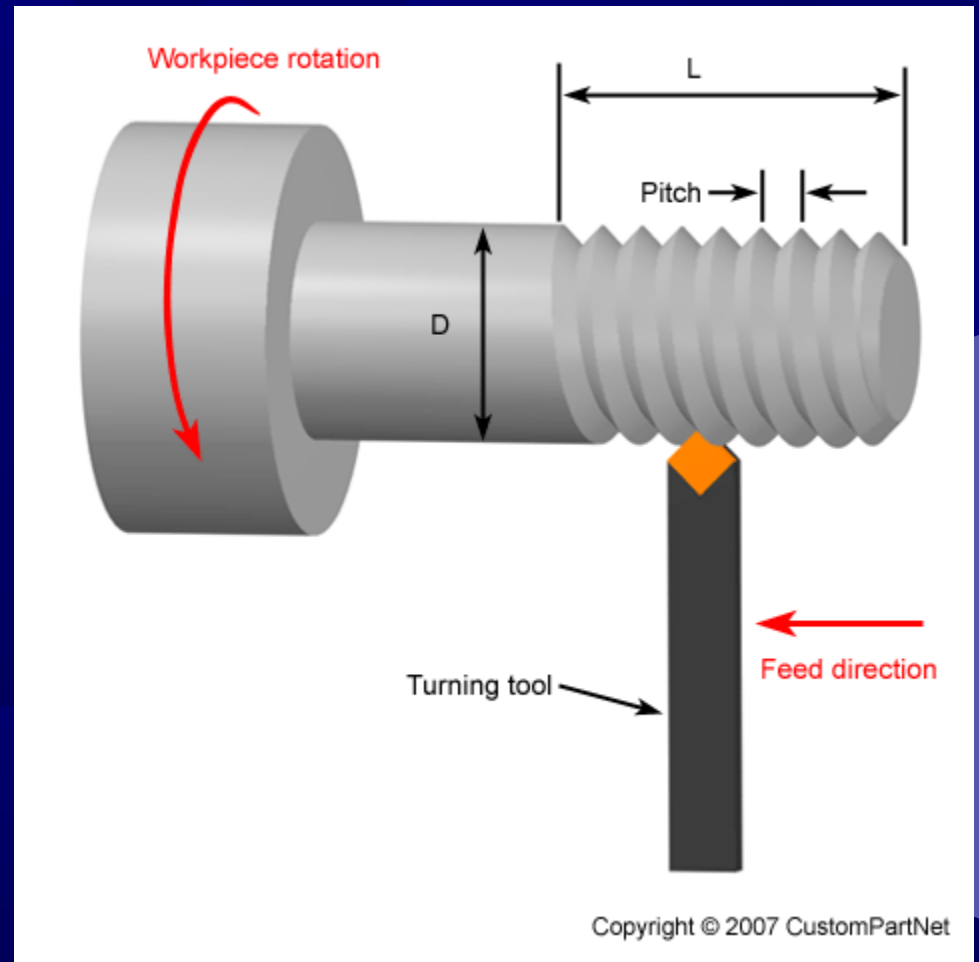

Boring

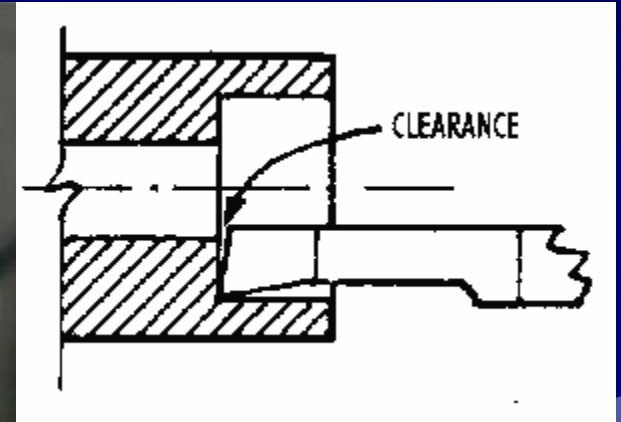
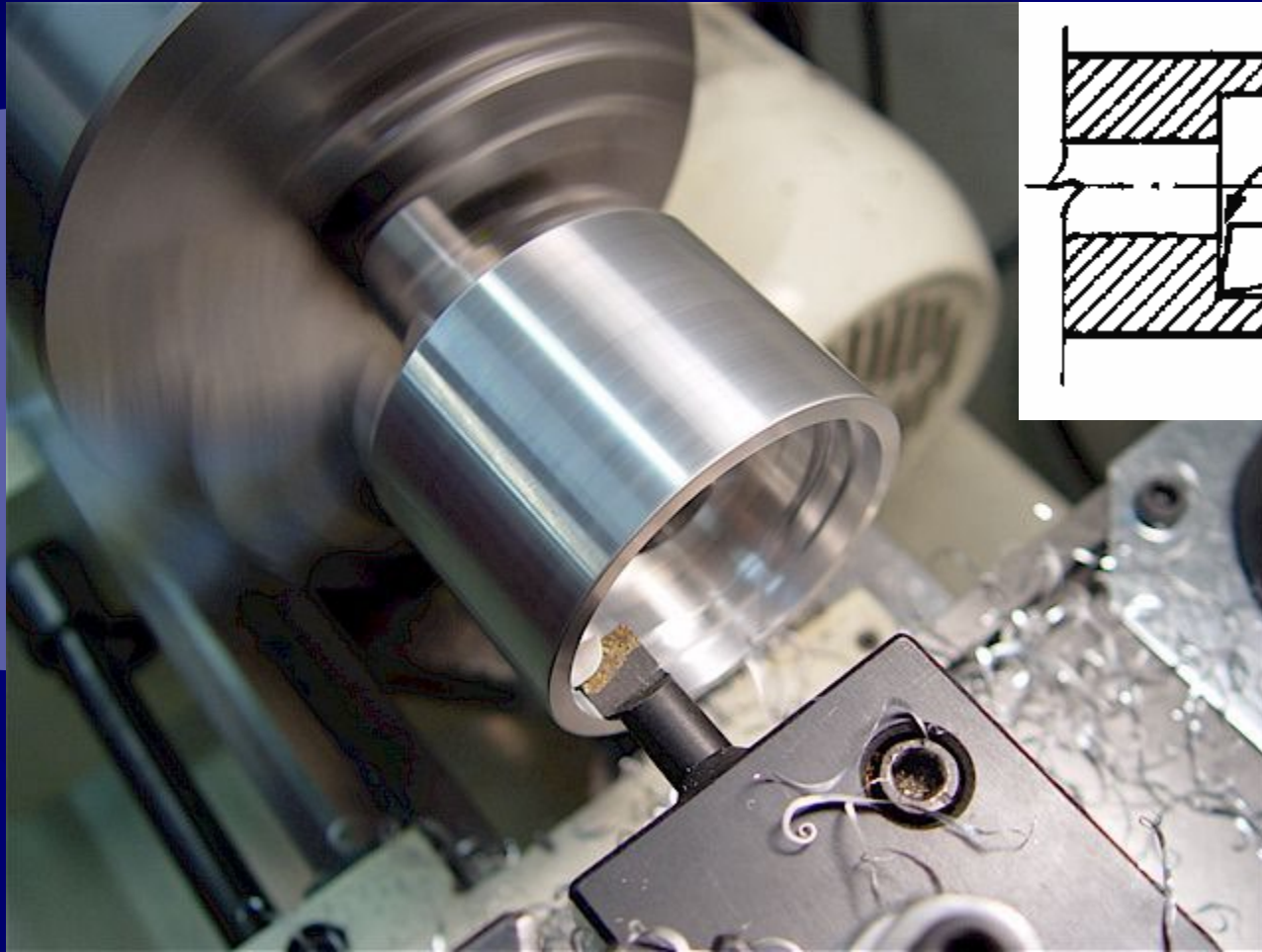

Parting/Grooving

